



AIR-BLOWERS INDUSTRIES SDN BHD

# AIR-BLOWERS

PROPELLER FAN SCAW SERIES



## Wall Mounted Axial-Propeller Fan

# SCAW

series

- ◆ Uniquely designed impeller integrated with external rotor motor.
- ◆ Speed controllable
- ◆ Slim, compact, light weight and high efficiency.
- ◆ Air guard provided.

## Introduction

**SCAW** Wall Mounted Axial-Propeller Fans are specially designed for **residential** and **commercial** ventilation application where noise level is of prime consideration. GTG Linear Speed Controller (Model C012 & C785) can be used to achieve specific performance requirements and desirable sound pressure level by linearly control its fan speed. Its uniquely designed fan blade integrated with high efficiency external rotor motor ensure light weight and excellent performance with low sound level.



### Square Plate

Constructed from steel plate, electro welded and protected with anti rust paint.

### Impellers

Made of steel with anti-rust paint

The motor and impeller are factory matched, statically and dynamically balanced.

### Motor

Moisture resistant, suitable for humid and damp environments.

Permanently lubricated ball bearings ensuring reliable and maintenance-free operation

Class F insulation,

Speed controllable

Built-in thermal protection device.

Protected to IP54 against dust and moisture.

### Accessories (Optional)

Linear Speed Controller

Model C012



For Fan Model  
- SCAW250  
- SCAW350

Model C785



For Fan Model  
- SCAW450  
- SCAW550  
- SCAW630

Automatic Shutter



Following a policy of continuous product improvement, we reserve right to modify products/data whenever necessary without prior notice.

AIR BLOWERS



## PERFORMANCE CURVE

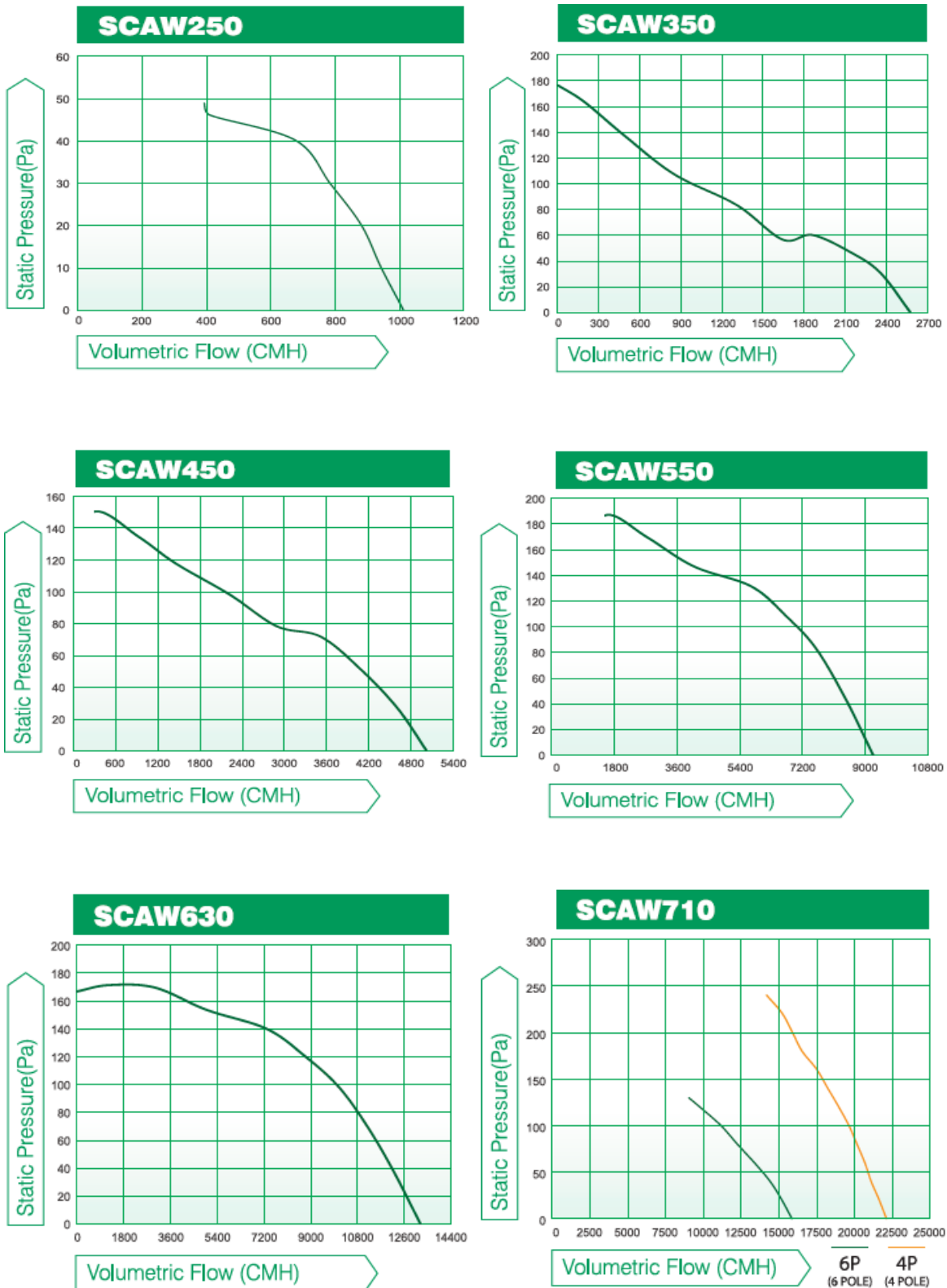

Following a policy of continuous product improvement, we reserve right to modify products/data whenever necessary without prior notice.



# AIR-BLOWERS

AIR-BLOWERS INDUSTRIES SDN BHD

PROPELLER FAN SCAW SERIES

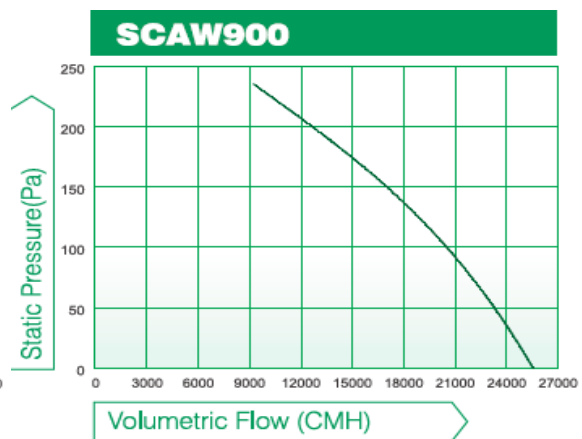
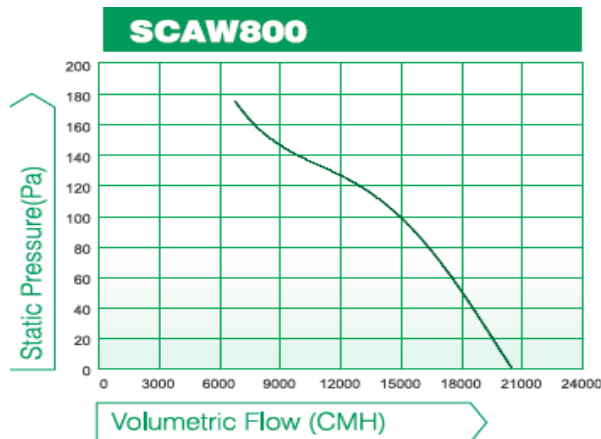

## Electrical Data

Model	SCAW250	SCAW350	SCAW450	SCAW550	SCAW630	SCAW710		SCAW800	SCAW900
						4P	6P		
<b>Volt / Phase / Hz</b>	230 / 1 / 50	230 / 1 / 50	230 / 1 / 50	230 / 1 / 50	230 / 1 / 50	415 / 3 / 50		415 / 3 / 50	415 / 3 / 50
<b>Input (W)</b>	50	194	521	892	1278	2700	1100	1650	2450
<b>Air Flow (CMH)</b>	1012	2603	5116	9238	13241	22105	15865	20491	25535
<b>Amps (A)</b>	0.22	0.68	1.15	2.45	3.50	4.70	2.35	3.65	4.70
<b>RPM</b>	1380	1370	1380	1310	1315	1350	900	880	870
<b>Sound Power, dB(A)</b>	70	79	85	84	88	104	80	101	102
<b>Sound Pressure, dB(A) at 3m</b>	50	59	64	64	67	84	60	81	82
<b>Weight (kg)</b>	4.2	7.3	10.3	17.6	24.0	39.0		42.0	51.0
<b>Speed Controller (OPTIONAL)</b>	YES	YES	YES	YES	YES	NO		NO	NO

## Wall Mounted Axial-Propeller Fan

### Dimension ( mm )

MODEL	A	B	C	D	ØE
SCAW250	370	320	55	258	7
SCAW350	485	435	85	360	9
SCAW450	575	535	100	460	11
SCAW550	725	675	135	560	11
SCAW630	805	750	150	630	11
SCAW710	850	810	170	710	14.5
SCAW800	970	910	210	795	14.5
SCAW900	1070	1010	205	920	14.5

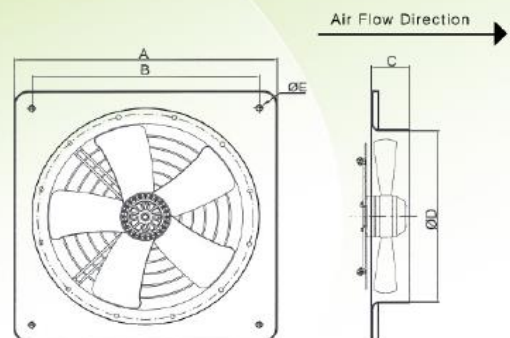

Following a policy of continuous product improvement, we reserve right to modify products/data whenever necessary without prior notice.