

Throttle valves, galvanised, manual, pneumatic and electric

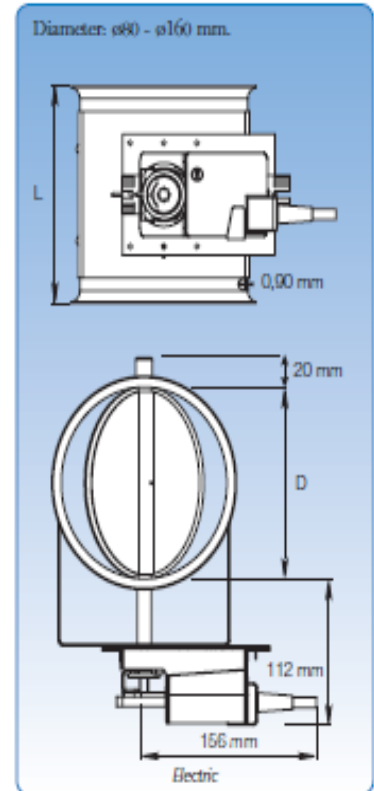
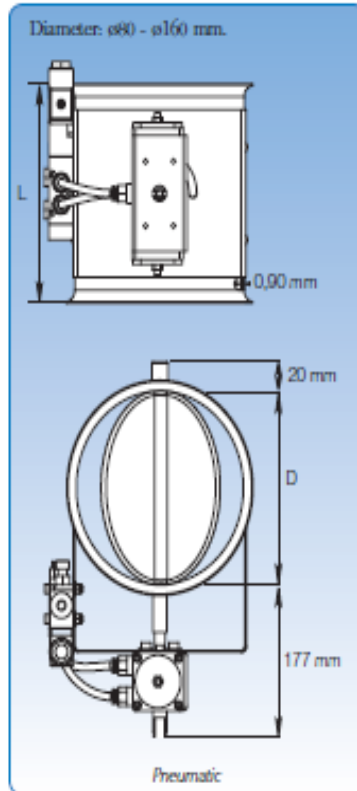
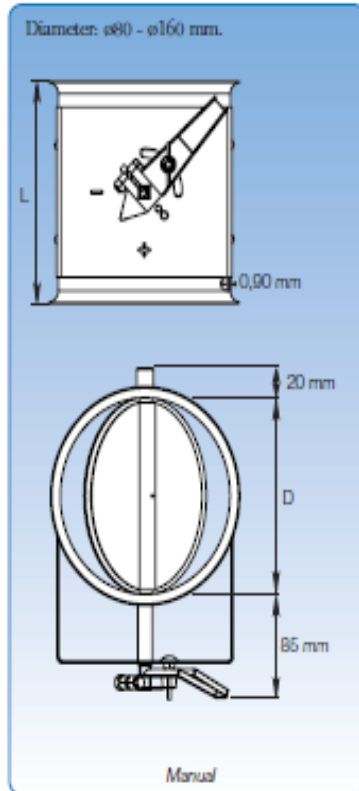

General

Galvanised throttle valves are made of 0,90 mm sheet metal and damper in double sheet. Throttle handle indicates damper position, and can be variably set between open and closed.

Available with natural rubber gasket.

Maximum closure 96%.

Larger throttle valves can be supplied upon request.

With pneumatic actuator

The damper is turned by a pneumatic actuator controlled by an electrically-operated valve.

Solenoid valve: monostable 5/2 valve with 1 x 230 V AC - 50/60 Hz electric coil or 24 V DC. Pneumatic pressure: 4-6 bar.

Valve setting indicators are available as an optional extra. Solenoid included as standard.

With electric actuator

The damper is operated by an electric motor activated by a changeover switch.

Valve setting indicators are available as an optional extra.

Electrical connection: 230 V AC - 50 Hz or 24 V DC.

Dimensions

Item no. (Man. stand)	Item no. (Man. tight)	Item no. (Pneu.)	Item no. (Elec.)	D mm	L mm	Weight (Man.) kg	Weight (Pneu.) kg	Weight (Elec.) kg
1570112	1510112	1510512	1510312	80	125	0,65	1,90	1,60
1571112	1511112	1511512	1511312	100	125	0,75	2,00	1,70
1572112	1512112	1512512	1512312	120	135	0,90	2,15	1,85
1573112	1513112	1513512	1513312	125	135	0,95	2,20	1,90
1574112	1514112	1514512	1514312	140	170	1,15	2,40	2,10
1575112	1515112	1515512	1515312	150	170	1,25	2,50	2,20
1576112	1516112	1516512	1516312	160	170	1,35	2,60	2,30

The item numbers stated are for throttle valves assembled using pull rings [Eb].

Throttle valves are also available for other assembly methods. See p. 6 for assembly methods.